

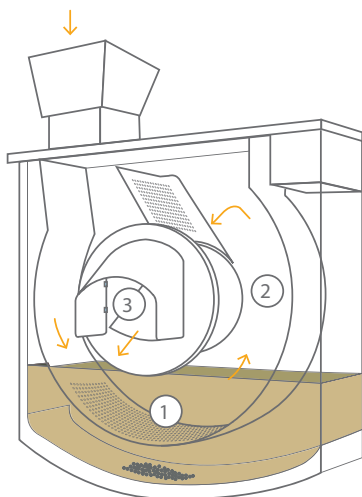

QUALITYFRY
AUTOMATIC SMART COOKING

iQ 6 MANUAL 4.6



ECOFRY SYSTEM – The Perfect Cycle

- 1. Frying** - Protects oil from light, water and oxygen, extending its useful lifespan.
- 2. Dry, golden and crispy** - With extraction of: Evaporated water, oil and excess solid particles.
- 3. Extraction** - The perfectly cooked product is extracted towards the output tray thanks to the blade.



QUALITYFRY
AUTOMATIC SMART COOKING

iQ6 MANUAL 4.6

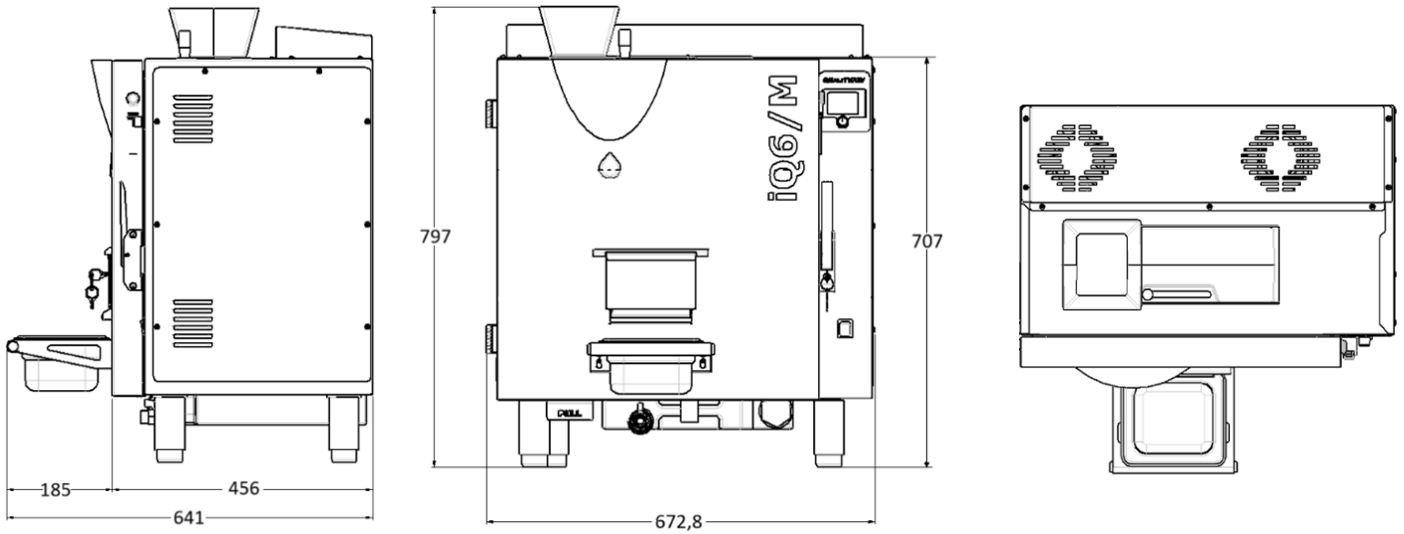

Dimensions

iQ6 Manual 4.6		
Width	26.5"	672.8 mm
Depth	17.9"	456 mm
Depth with tray	25.24"	641 mm
Height	31.38"	797 mm
Weight	160.9 lbs.	73 Kg
Weight packed	194 lbs.	88 Kg
Dimensions packed	800x600x1230 mm (WidthxDepthxHeight)	

Technical Specifications

Oil capacity	5.5 liters	
Hopper load	Mono product	500G por ration
Hourly production	Up to	13 Kg
Controls	2.4" screen	Programmable
	Rotary knob	time

To ensure correct functioning, the location of the machine must conform to the following minimum distances:

Top (to allow loading)	12"	300 mm
Sides	6"	150 mm

Installing the iQ6 Manual 4.6 in enclosed areas with limited or no access may void the warranty. Avoid placing the unit near heat sources (ovens, grills, etc.) or air conditioning vents; otherwise, a minimum distance of 1 meter must be maintained. Exhaust air is released from the top of the unit. The type of oil, its usage, cooking temperature, and the initial temperature of the product will affect cooking times and hourly output.

Continuous research leads to constant improvements; therefore, these specifications are subject to change without prior notice.

* The certification and testing for ventless operation and efficiency have been independently conducted and verified by SGS Laboratories. A copy of the report is available upon request. To ensure the IQ6 Manual continues to operate smoke-free, the daily, weekly, monthly, and annual cleaning procedures MUST be followed. The cylindrical activated carbon filter must be replaced at the recommended intervals. Failure to do so may void any warranty.

Electrical specification - Single Phase

iQ6 Manual 4.6	
Voltage	230 VAC
Frequency	50/60 Hz
Consumption	20 A
*Plug ¹	IEC 60309, 32 A-3 pin socket
*Plug ²	Bipolar plug with TT, 25 A
**Maximum input power	4600 W

*Recommended plug options, supplied without plugs

**3500 W option available

Maintenance schedule

- The oil must be filtered daily.
- The frying vat and all its components must be cleaned at least once a week.
- The condensation container must be emptied daily and washed once a month.
- The metal filter must be cleaned monthly.
- The cylindrical activated carbon filter must be replaced after 5,000 fry cycles, together with the equipment maintenance.
- Refer to the manual for more details regarding maintenance.

(Based on approximately 50 servings per day, higher-capacity units may require an increased cleaning schedule frequency)