

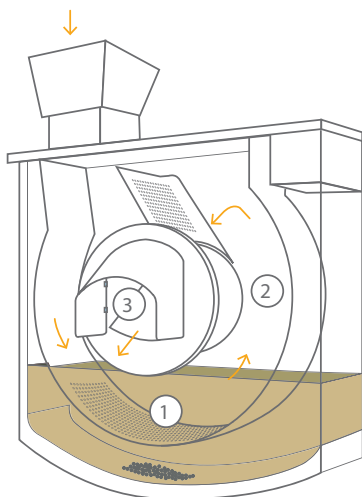

QUALITYFRY
AUTOMATIC SMART COOKING

iQ 645 FES CARROUSEL



ECOFRY SYSTEM – The Perfect Cycle

- 1. Frying** - Protects oil from light, water and oxygen, extending its useful lifespan.
- 2. Dry, golden and crispy** - With extraction of: Evaporated water, oil and excess solid particles.
- 3. Extraction** - The perfectly cooked product is extracted towards the output tray thanks to the blade.



QUALITYFRY
AUTOMATIC SMART COOKING

iQ 645 FES CARROUSEL

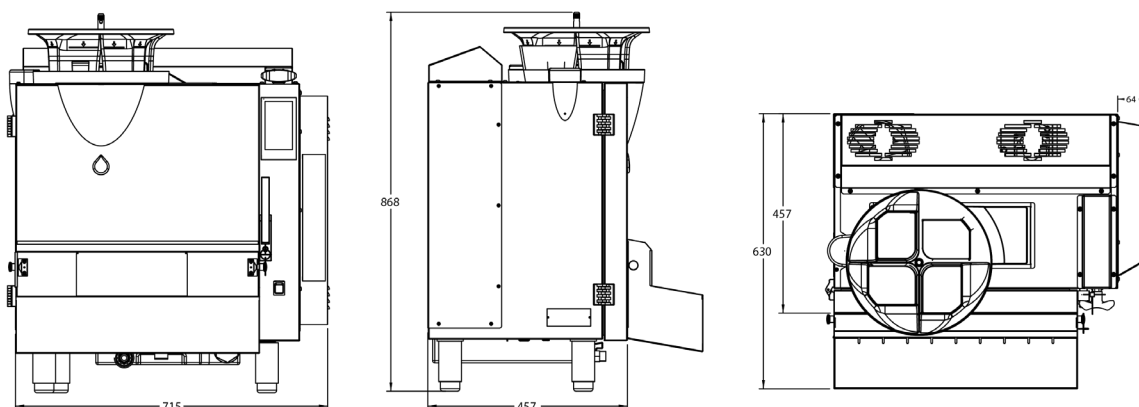

Dimensions

iQ 645 FES Carrousel		
Width	28.1"	715 mm
Depth	17.9"	457 mm
Depth with tray	24.8"	630 mm
Height	33.6"	856 mm
Weight	192 lbs.	87 Kg
Weight packed	225 lbs.	102 Kg
Dimensions packed	800x600x1230 mm (WidthxDepthxHeight)	

Technical Specifications		
Oil capacity	5.5 litres	
Hopper load	4 zone + 2 cooking	300g small portions 500g large portions
Hourly production	Up to	13 Kg**
Controls	5" Touch screen	8 pre-set times

To ensure correct functioning, the location of the machine must conform to the following minimum distances:

Top (to allow loading)	12"	300 mm
Sides	6"	150 mm

iQ 645 FES Carrousel installed in enclosed areas with limited or no access may invalidate warranty.

Avoid setting up the equipment near sources of heat (ovens, grills, etc.) or air conditioning outlets; otherwise, the minimum distance must be 1 metre. Exhaust air is vented from the top of the unit.

**Hourly production based on 6x6mm French fries. Oil type, oil age, cooking temperature and product starting temperature will effect cook times and hourly production.

Continuing research results in steady improvements; therefore, these specifications are subject to change without notice.

*Ventless and efficiency certification and testing has been carried out and independently verified by SGS Laboratories. A copy of the report is available on request.

To ensure the ventless operation of the iQ 645 FES Carrousel is maintained, the daily, weekly, monthly and annual cleaning procedures MUST be followed and the internal panel grease filter and cylindrical activated carbon filter need to be replaced at the recommended intervals. Failure to do so may invalidate any warranty.

Electrical specification - Single Phase

iQ 645 FES Carrousel	
Voltage	230 VAC
Frequency	50/60 Hz
Circuit breaker	20 A
*Plug/socket ¹	IEC 60309 , 32 A 3-pin socket
*Plug/socket ²	Bipolar plug with TT, 25 A
**Max input	4600 W

* Recommended plug options, shipped without them.
**3500 W option available

Fire Extinguishing System (FES)

General Description

The goal of the Fire Extinguishing System is to control a possible fire inside the deep fryer and to protect the operator and surroundings. The system is automatically activated and incorporates a pressure switch that detects the emptying of the cylinder, turning off the fans and cutting off the electrical voltage.

Maintenance

- The oil must be removed once a day.
- The frying chamber and all its elements must be cleaned once a week.
- The condensation drum must be emptied every day and cleaned once a month.
- The metal filter must be cleaned once a month.
- The cylindrical charcoal filter must be replaced every 5000 fryings, along with the maintenance of the equipment.
- Cleaning the fuse once a week.
- Review of the extinguishing system according to the country's regulations.
- Consult manual for more details related to maintenance.

(Based on approximately 50 portions per day, equipment with higher production levels may require the frequency of cleaning to be increased)